

CARGA DE BATERIA • BATTERY RECHARGE • CHARGE DE LA BATTERIE • AUFLADUNG DER BATTERIE • DE ACCU-OPLADER • CARGA DE BATERIA • CARICA DELLA BATTERIA



- REALIZAR POR UN ADULTO
- THIS SHOULD BE DONE BY AN ADULT
- A RÉALISER PAR UN ADULTE
- DIES IST VON EINEM ERWACHSENEN AUSZUFÜHREN
- UIT TE VOEREN DOOR EEN VOLWASSENE
- A REALIZAR POR UM ADULTO
- DEVE REALIZZARLO UN ADULTO



- POR FAVOR, SIGA EstrictAMENTE LA SECUENCIA DE RECARGA DE LA BATERIA.
- PLEASE FOLLOW CAREFULLY THE INSTRUCTIONS FOR RE-CHARGING THE BATTERY; FAILURE TO COMPLY WITH THIS PROCEDURE WILL DAMAGE THE BATTERY. THE BATTERY IS NOT COVERED UNDER THE WARRANTY.
- VEUILLEZ SUIVRE À LA LETTRE SCRUPULEUSEMENT LA PROCÉDURE DE RECHARGEMENT DE LA BATTERIE.
- BEI DER AUFLADUNG DER BATTERIE FOLGEN SIE BITTE GENAUESTENS DER REIHENFOLGE.
- VOLG A.U.B. DE OPLAADVOLGORDE VAN DE BATTERIJ STRIKT OP
- POR FAVOR, SIGA ATENTAMENTE A SEQUENCIA DE RECARGA DA BATERIA
- PER FAVORE SEGUA ATTENTAMENTE LA SEQUENZA DELLA RICARICA DELLA BATTERIA

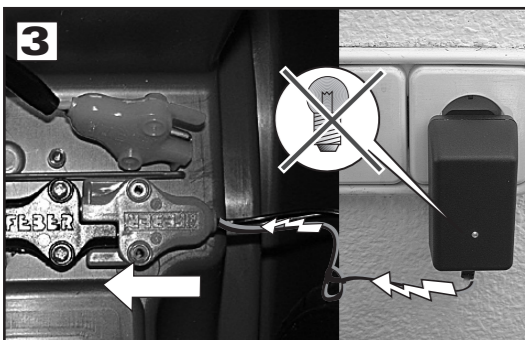
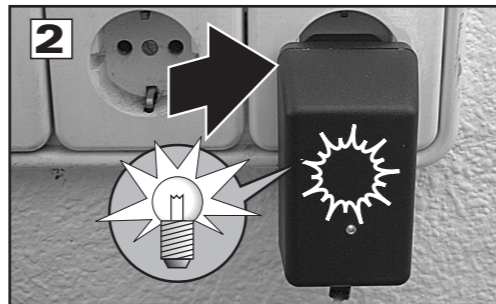
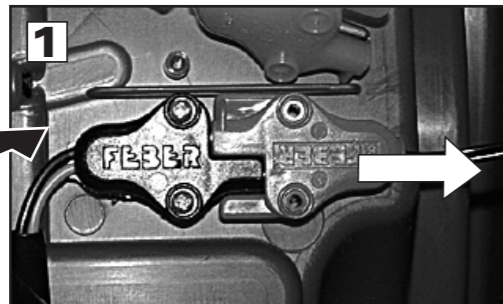
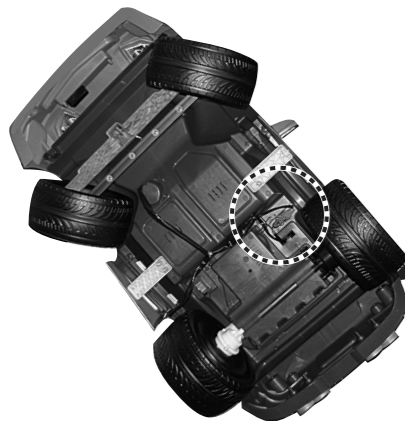

- EL TIEMPO DE DURACION DE LA RECARGA ES HORAS
- RECHARGING TIME IS HOURS
- LA DURÉE DE LA RECHARGE EST D'ENVIRON HEURES
- DIE LADEZEIT IST VON STUNDEN
- OPLAAD-TIJD UUR
- O TEMPO DE DURAÇÃO DA RECARGA É HORAS
- IL TEMPO DI DURATA DELLA RICARICA È ORE



14-17 APPROX.

CUANDO LA LUZ PILOTO SE VUELVA A ENCENDER, LA BATERIA ESTARÁ CARGADA. ONCE THE BATTERY HAS BEEN CHARGED, THE CHARGER PILOT WILL TURN ON. QUAND LA BATTERIE SERA ENTIEREMENT CHARGÉE, LA LUMIÈRE SE RALLUMERA AUTOMATIQUEMENT. WENN DAS SIGNALLICHT WIEDER AUFLEUCHTET IST DIE BATTERIE AUFGEADEN. WANNEER HET LICHTJE TERUG GAAT BRANDEN, IS DE BATTERIJ VOLLEDIG OPGELADEN. QUANDO A LUZ PILOTO SE VOLTAR A ACENDER, A BATERIA ESTARÁ CARGADA. QUANDO LA SPIA SI ACCENDE DI NUOVO, LA BATTERIA SARÀ CARICA.

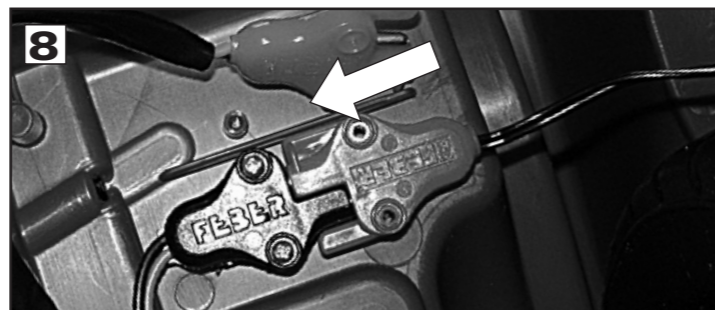
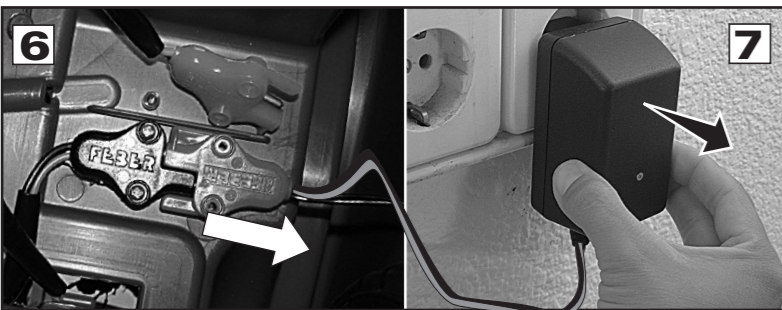
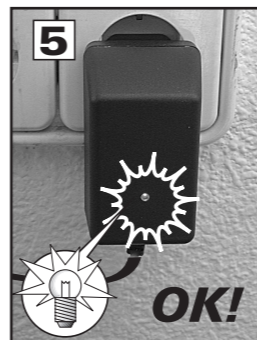

SUSTITUCIÓN DE LA BATERÍA USADA • REMOVE EXHAUSTED BATTERIES FROM THE TOY • CHANGEMENT DE LA BATTERIE USAGÉE DU JOUET • DIE ERSETZUNG DER GEBRAUCHTEN BATTERIE • ERVANGING VAN DE GEBRUIKTE BATTERIJ • SUBSTITUIÇÃO DA BATERIA USADA • SOSTITUZIONE DELLA BATTERIA USATA



- REALIZAR POR UN ADULTO
- THIS SHOULD BE DONE BY AN ADULT
- A RÉALISER PAR UN ADULTE
- DIES IST VON EINEM ERWACHSENEN AUSZUFÜHREN
- UIT TE VOEREN DOOR EEN VOLWASSENE
- A REALIZAR POR UM ADULTO
- DEVE REALIZZARLO UN ADULTO



- ¡ADVERTENCIA! NO CORTOCIRCUITAR LA BATERIA.
- WARNING! NOT TO SHORT-CIRCUIT SUPPLY TERMINALS
- ATTENTION! NE PAS COURT-CIRCUITER LES BORNES DE L'ACCUMULATEUR
- WARNUNG! BATTERIEN NICHT KURZSCHLIEßEN.
- WAARSCHUWING! DE BATTERIJ NIET KORTSLUITEN.
- AVISO! NÃO PROVOCAR CURTO-CIRCUITO NA BATERIA.
- AVVERTENZA! NON FAR FARE CORTO CIRCUITO ALLA BATTERIA.

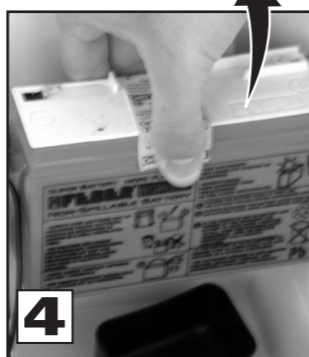
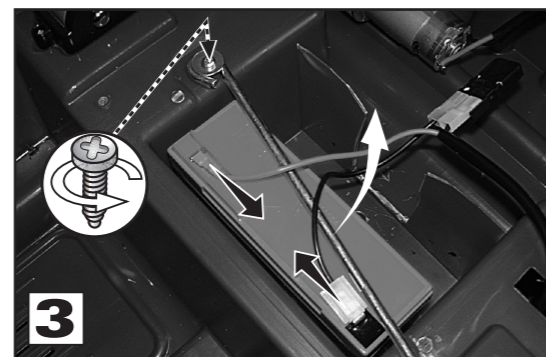
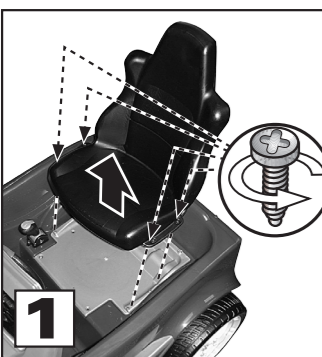

- ¡ADVERTENCIA! NO CONVIENE A NIÑOS MENORES DE 36 MESES. POR CONTENER PIEZAS PEQUEÑAS QUE PUEDEN SER INGERIDAS O INHALADAS.
- WARNING! NOT SUITABLE FOR CHILDREN UNDER 36 MONTHS. SINCE IT CONTAINS SMALL PIECES THAT CAN BE INGESTED OR INHALED. CONTAINS POTENTIALLY HAZARDOUS SHARP EDGES OR SHARP POINTS, BEFORE THE ASSEMBLING. THIS TOY IS TO BE ASSEMBLED BY AN ADULT.
- AVERTISSEMENT! NE CONVIENT PAS AUX ENFANTS DE MOINS DE 36 MOIS. CAR IL CONTIENT DES PETITES PIÈCES POUVANT ÊTRE AVALÉES OU INHALÉES.
- WARNUNG! NICHT GEEIGNET FÜR KINDER UNTER 36 MONATEN. DIE KLEINEN TEILE KÖNNEN IN MUND ODER NASE EINGEFÜHRT WERDEN.
- WAARSCHUWING! GEZIEN DE TECHNISCHE EIGENSCHAPPEN VAN HET SPEELTUIG IS HET NIET AAN TE RIJDEN VOOR PEUTERS ONDER DE 36 MAANDEN.
- AVISO! NÃO É ACONSELHÁVEL PARA CRIANÇAS MENORES DE 36 MESES, VISTO CONTER PEÇAS PEQUENAS QUE PODEM SER INGERIDAS OU INALADAS.
- AVVERTENZA! NON È ADEGUATO PER BAMBINI MINORI DI 36 MESI PERCHÉ CONTIENE COMPONENTI DI PICCOLO TAGLIO CHE POSSONO ESSERE INGERITI O INALATI.

ROADSTER Wave HAZUR

DISEÑO C&D

© 2005

+3 AÑOS YEARS ANS JAHRE JAAR ANOS ANI

6V

REF.052178

TIEMPO DE JUEGO: RUNNING TIME: DURÉE DE FONCTIONNEMENT: SPIELZEIT: RIJTLID: TEMPO DE JOGO: TEMPO DI GIOCO: **1:30'** (APPROX.)

PESO MÁXIMO RECOMENDADO: RECOMMENDED MAXIMUM WEIGHT: POIDS MAX. RECOMMANDÉ: EMPFOHLENES GEWICHT: MAXIMUM AANBEVOLEN GEWICHT: PESO MÁXIMO RECOMENDADO: PESO MASSIMO RACCOMANDATO: **50kg**

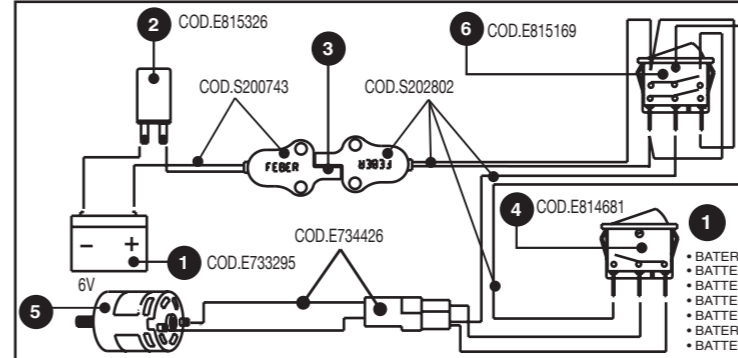

- 1 COD.E733295
 - 2 COD.E815326
 - 3 COD.S200743
 - 4 COD.E814681
 - 5 COD.E734426
 - 6 COD.E815169
- BATERIA
 - BATTERY
 - BATTERIE
 - BATTERIJ
 - BATERIA
 - BATTERIA
- DISYUNTOR
 - CUT-OUT SWITCH
 - COUPE-CIRCUIT
 - TRENNSCHALTER
 - STROOMONDERBREKER
 - DISJUNTOR
 - SCONNESSIONE
- CLAVIAS DE CARGA
 - CHARGING PINS
 - FICHES BATTERIE
 - LADESTÖPSEL
 - OPLAADCONTACTEN
 - FICHA DE CARGA
 - SPINE DI CARICA
- PULSADOR ACCELERADOR
 - ACCELERATOR BUTTON
 - PEDALE D'ACCELERATEUR
 - BESCHLEUNIGUNGSDRÜCKER
 - RIJDRUKKNOP
 - BOTÃO ACCELERADOR
 - PULSANTE ACCELERATORE
- MOTOR
 - MOTEUR
 - MOTORE
- PALANCA DE CAMBIO
 - GEAR STICK
 - LEVIER DE VITESSES
 - GANGSCHALTUNGSEBEL
 - VERSNELLINGSHENDEL
 - ALAVANCA DAS MUDANÇAS
 - LEVA DEL CAMBIO

CONTENIDO • CONTENTS • CONTENU • INHALT • INHOUD • CONTEÚDO • CONTENUTO

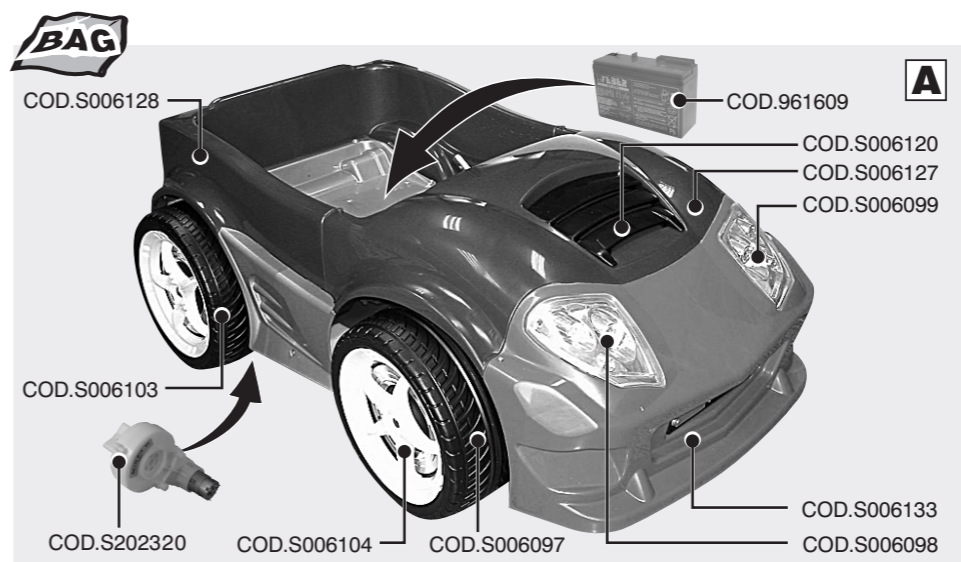

- COD.S006128
 - COD.S006120
 - COD.S006127
 - COD.S006099
 - COD.S006103
 - COD.S202320
 - COD.S006104
 - COD.S006097
 - COD.S006133
 - COD.S006098
 - COD.S202807
 - COD.S202563
 - COD.S201772
 - COD.S006118
 - COD.S006121
 - COD.S202806
 - COD.S005325
 - COD.S202821
- F
 - G
 - H
 - I
 - J
 - K
 - L
- CARGADOR BATTERY CHARGER CHARGEUR LADEGERÄT LADER CARREGADOR CARICABATTERIA
- 961616 CEE
961623 U.S.A
961630 U.K.
- 18x 5,1x20
2x 4,8x38
1x 3,1x13



**MONTAJE · ASSEMBLY · ASSEMBLAGE · BEDIENUNGSANLEITUNG
· MONTAGE · MONTAGEM · MONTAGGIO**

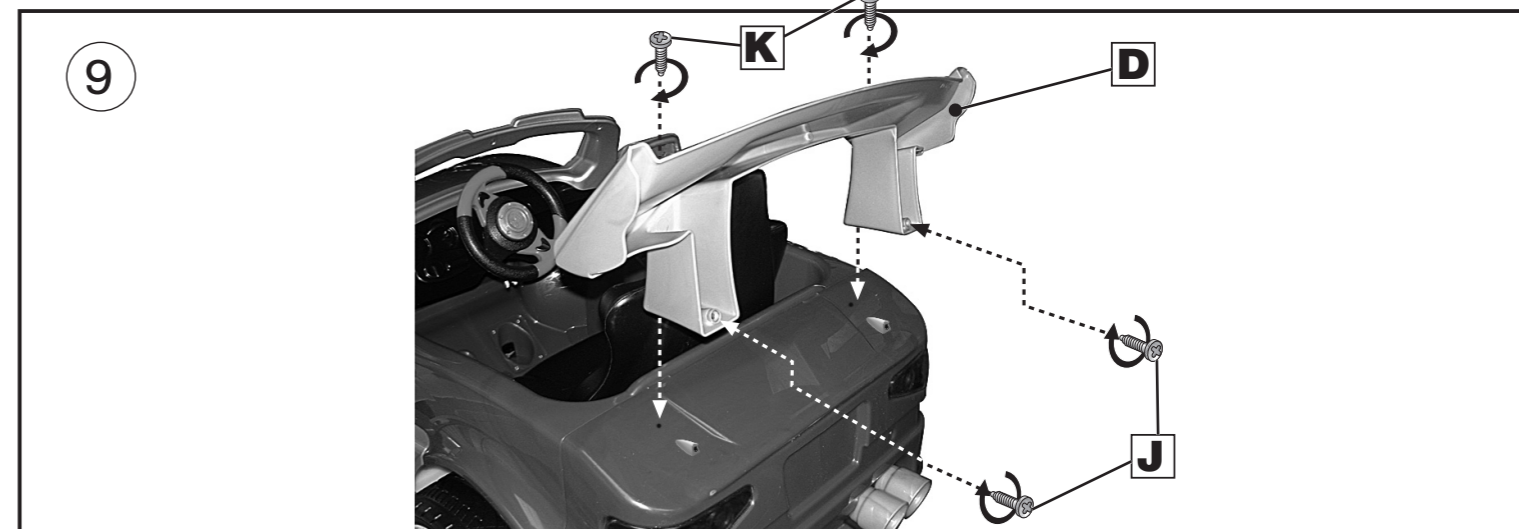
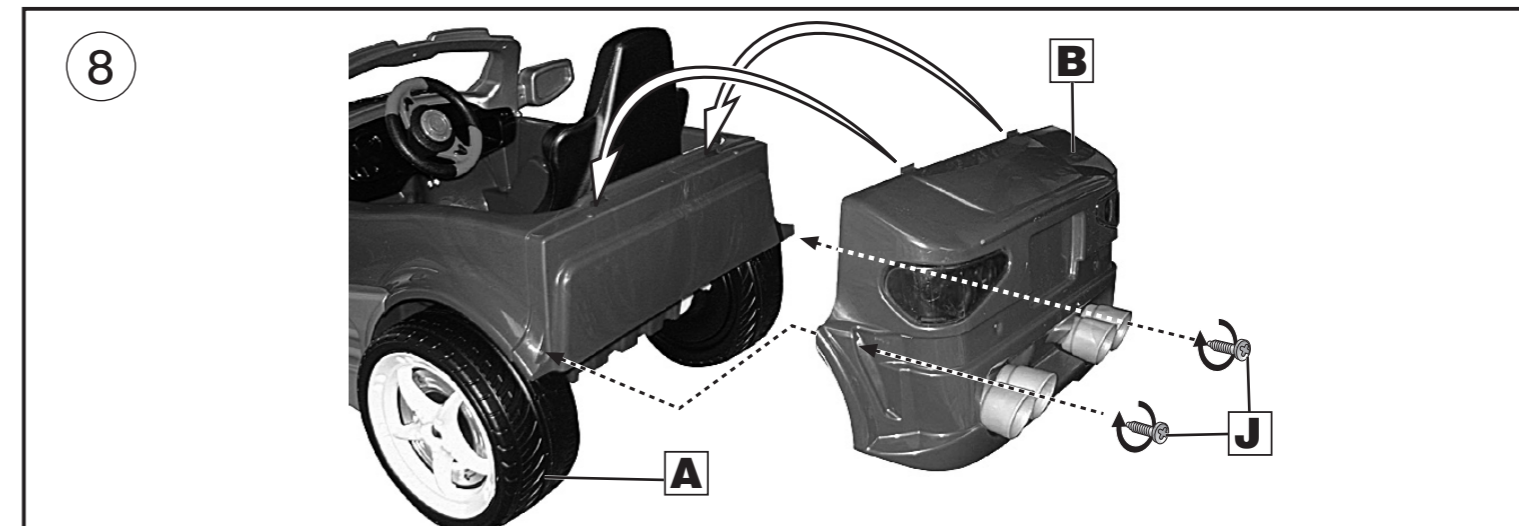
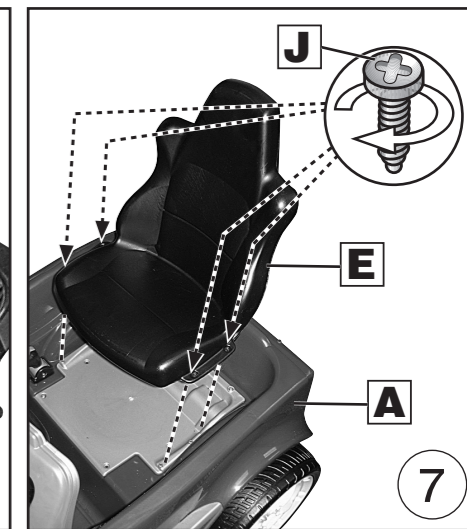
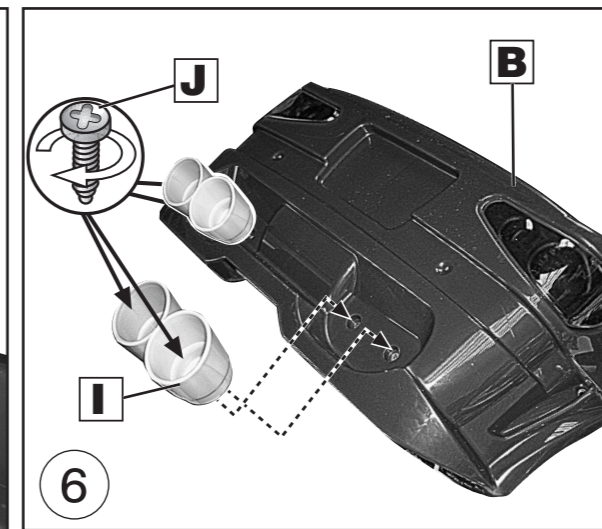
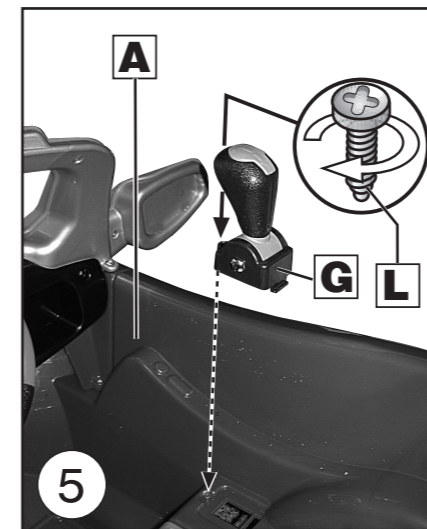
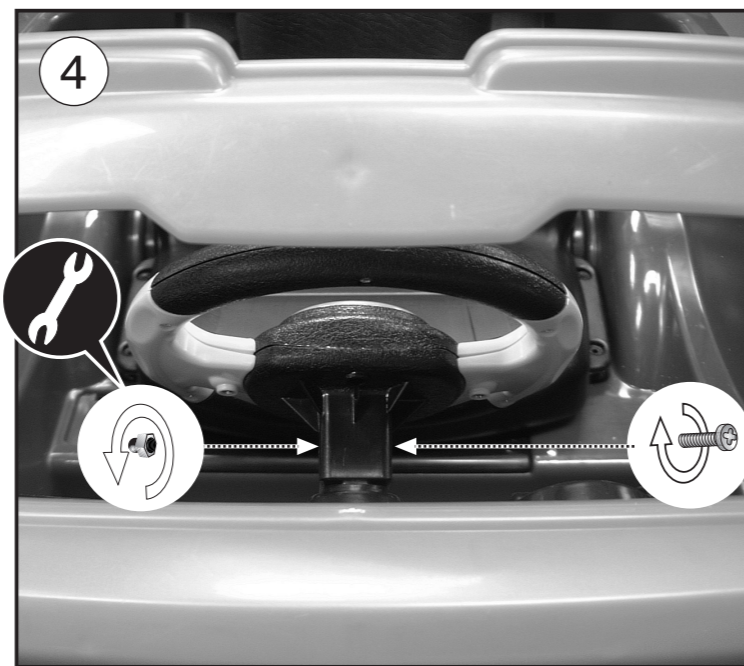
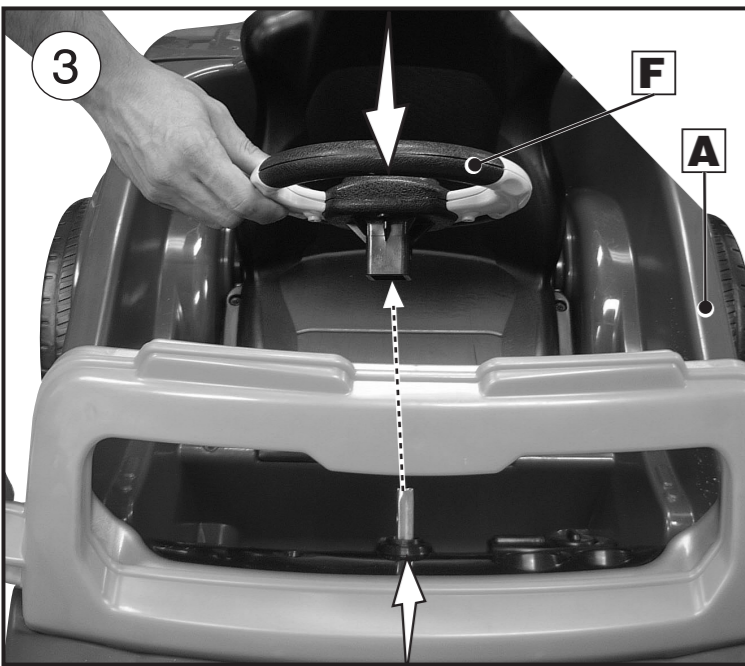
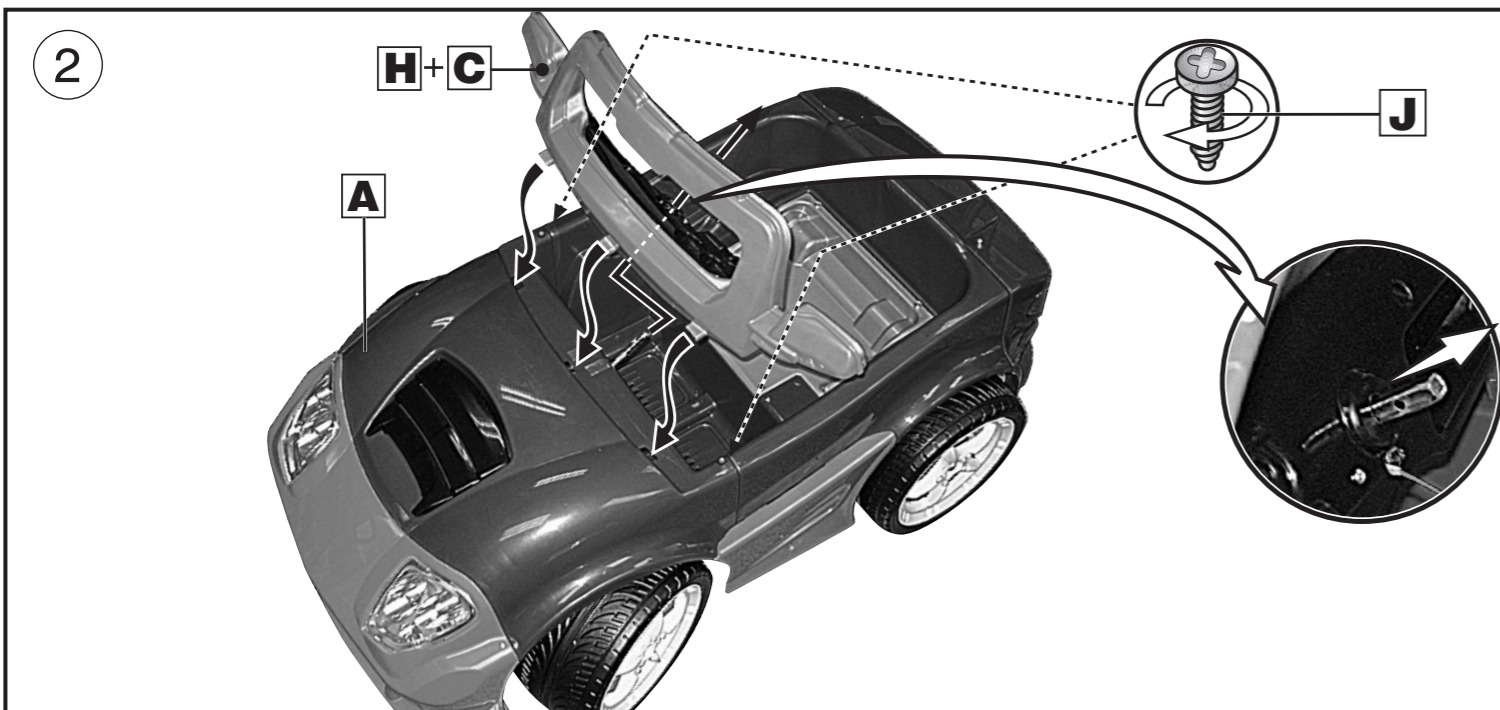
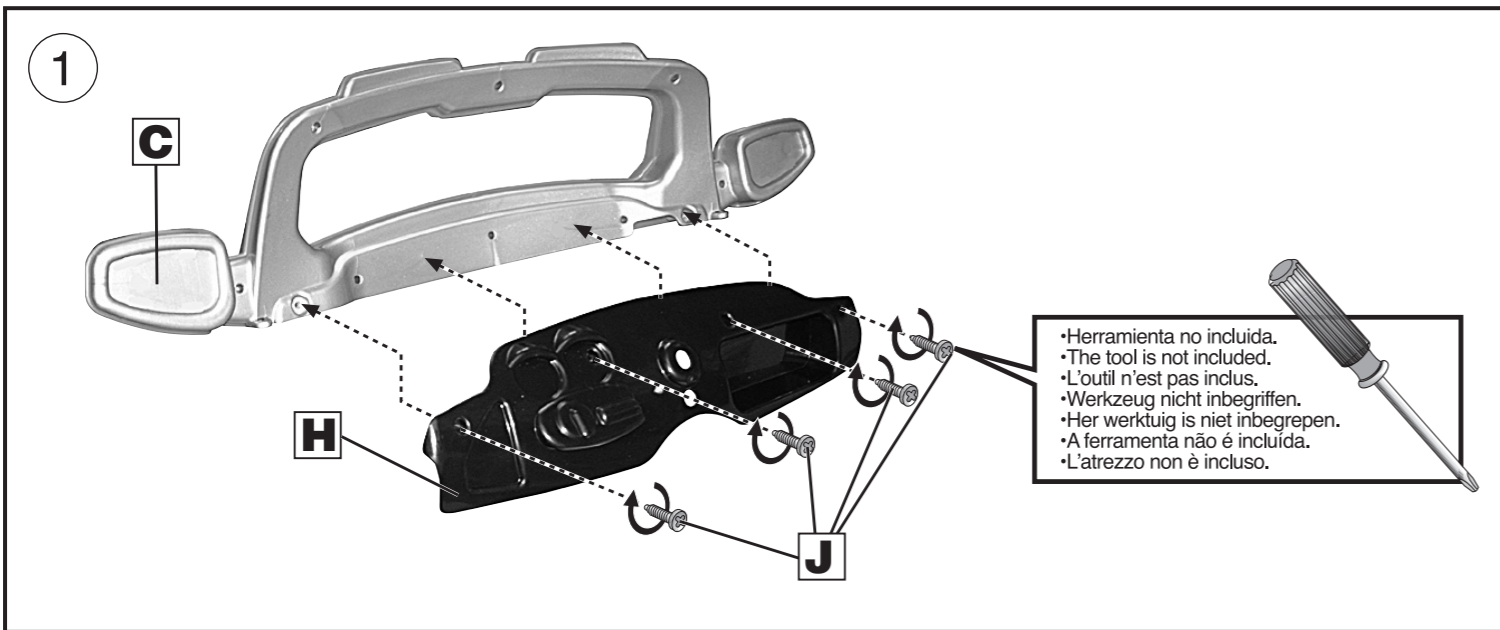

**·CONEXIÓN DE LAS CLAVIJAS · CONNECTION OF PINS · BRANCHEMENT AUX BORNES · ANSCHLUSS DER STÖPSEL
·AANSLUITING VAN DE OPLAADCONTACTEN · LIGAÇÃO DAS FICHAS · CONNESSIONE CON LE SPINE**

- ⚠
- REALIZAR POR UN ADULTO
 - THIS SHOULD BE DONE BY AN ADULT
 - A REALISER PAR UN ADULTE
 - DIES IST VON EINEM ERWACHSENEN AUSZUFÜHREN
 - UIT TE VOEREN DOOR EEN VOLWASSENE
 - A REALIZAR POR UM ADULTO
 - DEVE REALIZARLO UN ADULTO

